

RADIANT MOBILE

RADIANT MOBILE

MODEL NO: 10070X01

Hand poured, rippled glass crystal puddles suspended on custom-machined hardware and rigid, linear structure, illuminated by integrated, refracting light.

AS SHOWN (IN PHOTO)

6 glass pieces, 3 tiers - approx. dimensions 60"W x 60"D x 31"H
Glass - clear with iridescence
Metal - aged blackened metal

DIMENSIONS

Available in four sizes:

4 glass pieces, 2 tiers - approx. dimensions 48"W x 48"D x 18"H
4 glass pieces, 2 tiers - approx. dimensions 72"W x 36"D x 18"H
6 glass pieces, 3 tiers - approx. dimensions 60"W x 60"D x 25.5"H
6 glass pieces, 3 tiers - approx. dimensions 84"W x 48"D x 25.5"H

Glass - large approx. 12.5"W x 11.5"D x .75"H
small approx. 11"W x 10"D x .75"H

Glass dimensions may vary slightly due to hand poured process

ELECTRICAL

Integrated LED
2700K, 2W per glass, 50,000hrs average life
Driver onboard
120-277VAC universal input
Dimmable: Triac, ELV, 0-10V
Requires 4" x 2-1/8"D octagon junction box

AVAILABLE FINISHES

Glass Crystal Color - clear

Glass Crystal Finish - standard or with iridescence

Metal - natural metal, tarnished metal, aged blackened metal,
natural brass*, tarnished brass*, aged blackened brass*
polished metal*, polished brass*

*premium finish - refer to price guide for additional charges

ADDITIONAL NOTES

General lead time for standard finishes is 8-10 weeks. Optional 4-6 week lead time available for standard finishes. Updated lead times provided at time of formal quoting. Covered by EU, UK, and Chinese design registrations.

UL listed



4 PIECE, 2 TIER 48"W x 48"D x 18"H

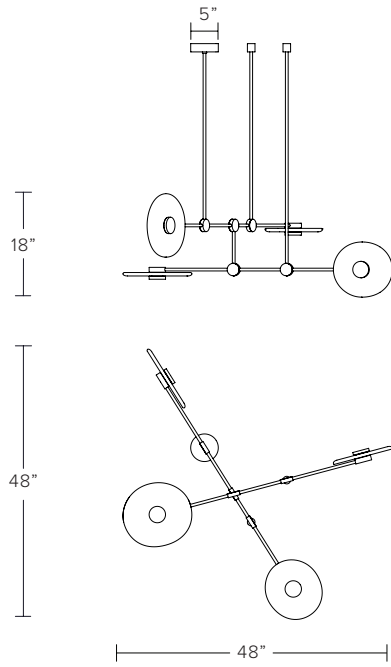

4 PIECE, 2 TIER 72"W x 36"D x 18"H

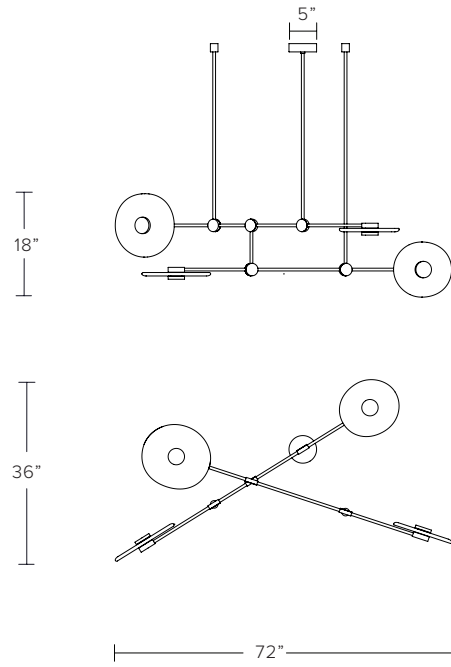

6 PIECE, 3 TIER 60"W x 60"D x 25.5"H

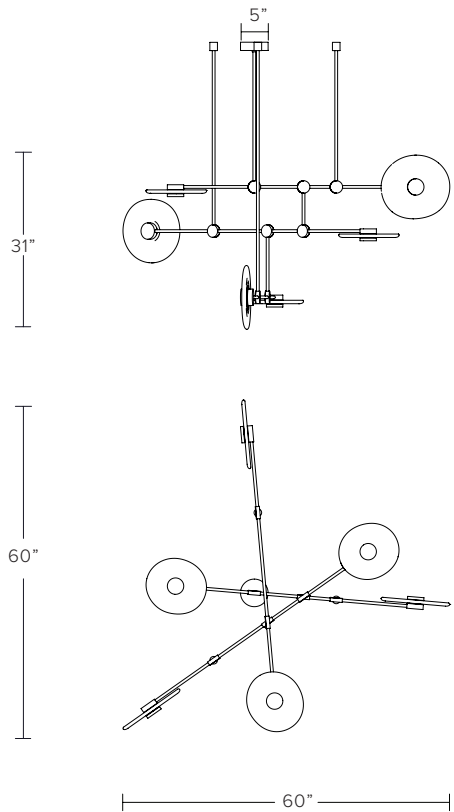

6 PIECE, 3 TIER 84"W x 48"D x 25.5"H

